

## SERVICE SOLUTIONS // HOW TO

# HOW TO ENSURE CORRECT LUBRICATION ON YOUR CO2 STUNNER

### Weekly lubrication of the gondols

1. Open the two inspection doors to access the inside of the CO2 Stunner (the doors are mechanically locked and equipped with safety switches, also part of the emergency stop circuit and the machine will stop when the doors are open)
2. Step onto the service bridge - having a gondola on each side of you
3. Use grease gun on below grease nipples - **picture A**  
**NOTE:** Grease nipple **C** is on both sides of the gondola
4. Perform at least 7 pumps on each grease nipple, or until grease comes out of the bearing and bushing

### Daily inspection/lubrication of oil and grease container

1. Check the oil/grease level in the lubrication system - **picture B**
2. Remove the top lid on the oil container - marked with a red arrow - and refill via the filter.  
**NOTE:** If **NO** oil has been used contact Frontmatec as there is a risk of your mainchain breaking
3. To refill the grease container - marked with a green arrow - use a grease gun and fill until the maximum mark is reached.

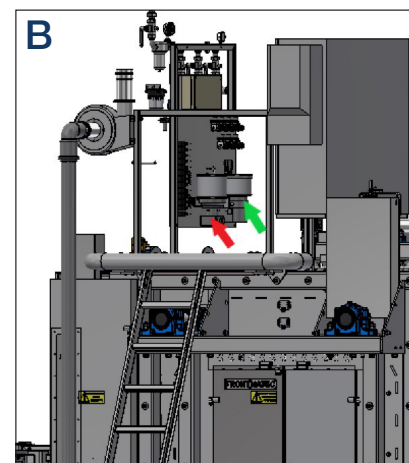
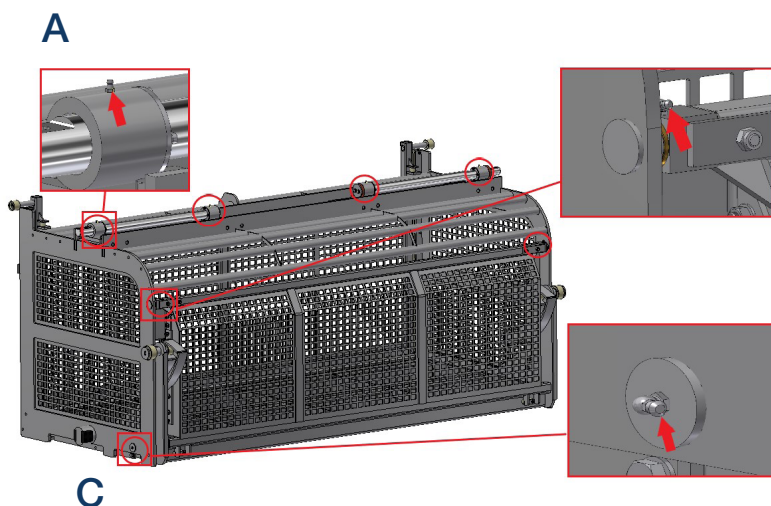

Oil: SLBI-I  
Grease: SLBG-A

## CONTACT

Central/Eastern Europe  
+49 252 185 070  
service.de@frontmatec.com

Northern Europe, Kolding  
+45 36 999 099  
service.kol.dk@frontmatec.com

Northern Europe, Tandslet  
+48 227 345 551  
service.tan.dk@frontmatec.com

Southern Europe  
+34 932 643 800  
service.es@frontmatec.com

Western Europe  
+31 886 294 000  
service.nl@frontmatec.com